

BETTER SAFE THAN SORRY



ARC FAULT CIRCUIT INTERRUPTION



FIRE HAZARD PREVENTION

TRUST IS A GOOD THING, BUT CONTROL IS A BETTER ONE.

The **world of energy production is changing**, luckily for the better! With solar energy being on the rising path, the **safety of all components** involved in the process became more and more important over the last years.

Especially the field of **fire hazard prevention** gained a lot of investigation. At PV plants, fire hazards are mostly caused by **arc faults which may occur due to several reasons**, like product failure or natural phenomenons like lightning.

Sungrow's Arc Fault Circuit Interruption Technology tackles the roots of the problem and shuts down the system **before arc faults may occur**.



PLANT LIFETIME EXTENSION



INTEGRATED SOLUTION

Available for
SG 33 / 40 / 50 / 110 CX

Inverter models from
VERSION TYPE V112

Automatic shutdown
IN LESS THAN 200 ms

Activation via app
FAST & EASY

SAFETY AS A STANDARD NOT AS A PRIVILEGE

INTEGRATED & DESIGNED TO SAVE MONEY

The new Arc Prevention Technology comes as standard with the SG 33 / 40 / 50 CX. As for the SG110CX, this will be an optional feature. The Arc Fault Circuit Interruption can be activated in the iSolarDesign app with only a few steps.

ARC PREVENTION TECHNOLOGY

In case of an arc fault (HF noise) the switches in the inverter will open and interrupt the circuit to guarantee safety to the solar system. In case of arc fault detection a professional technician should investigate the reason.

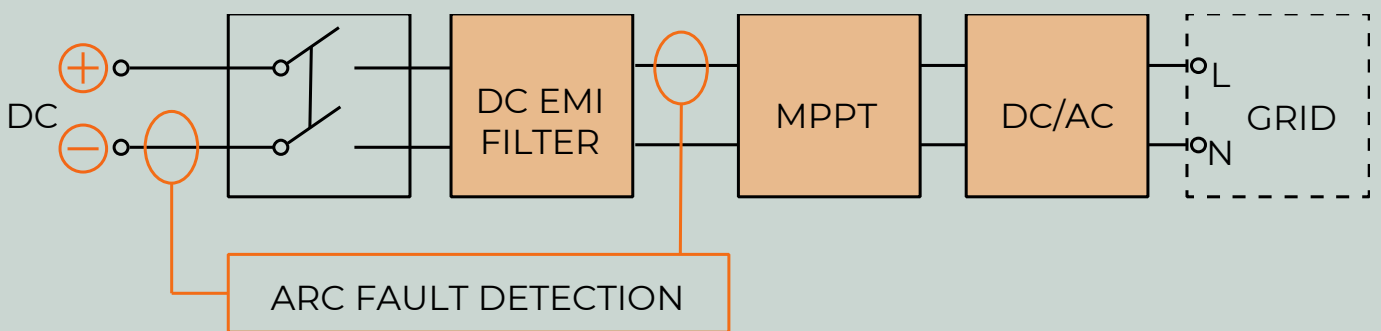

ARC FAULT CIRCUIT INTERRUPTION SET UP

1 OPEN iSolarCloud APP



2 DIRECT CONNECTION

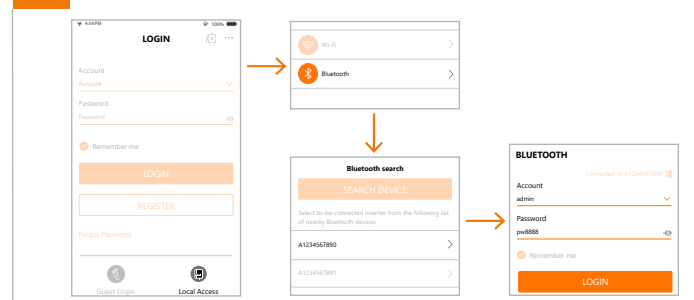

3 OPEN SETTINGS

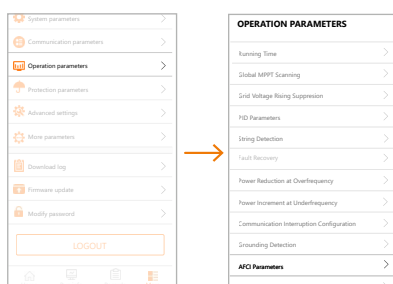

4 ACTIVATE ARC FAULT INTERRUPTION

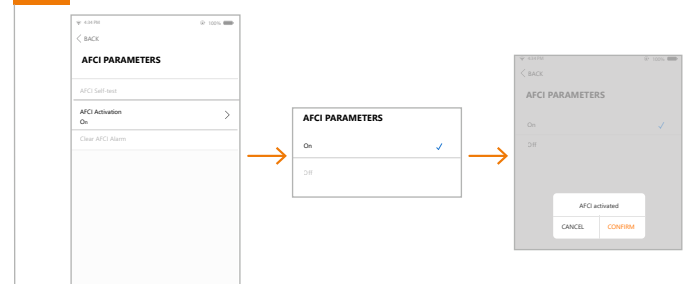

MORE ANSWERS



Eleonora Potestio

Technical Presales &
Product Owner Commercial

1

What causes arc faults?

Arc faults may arise from product or planning failures, installation mistakes as well as external influence (i.e. lightning). They are mainly caused by loose or poor contacts, broken wiring, moisture and corrosion of wires or aging of insulating materials.

2

Is arc fault detection mandatory?

In Europe there is currently no standard for arc fault detection for inverters. The standard IEC 63027 "DC Arc Detection & Interruption in Photovoltaic Power Systems" is currently under development. The norm aims to provide requirements for AFCI in PV systems. Therefore, arc fault detection may be required in the future. Our inverters currently follows the UL 1699B standard.

3

What happens when an arc fault is detected?

Once the arc detection function has been activated, it will identify a fault arc and will interrupt the circuit in less than 200 ms. This feature improves personal safety, protects equipment and prevents damage of the solar system.

4

How is the inverter reconnected after an arc detection event?

In case of an arc fault event, the inverter will clear the alarm after five minutes and will restart automatically. If the arc is still detected, the alarm will be reactivated and the circuit will be once again cut off. Automatic restart will be carried out for 5 times, afterwards a manual reactivation will be required.

5

Can older models be retrofitted with the AFCI technology?

Older versions like V11 of the CX Series cannot be retrofitted with this feature. Only the CX inverters of version V112 are equipped with Arc Fault Circuit Interruption.

6

How are false alarms avoided?

Sungrow adopts three-level detection and two-level closed-loop algorithms for arc detection. Additionally, in case the system frequently shows false faults or the threshold wants to be changed for technical reasons, the value can be changed. Please contact Sungrow for further support.